

A-TID -1572

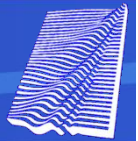

Areté
Associates

Areté Associates

We know systems... we know lasers



Areté produces diode pumped solid-state lasers that are more efficient, compact, and reliable than legacy systems. Areté's *A-TID* series compact laser is perfectly suited to Short Wave Infrared imaging and other laser radar applications. The innovative MOPA configuration provides high energy, short duration pulses at 1572nm. The laser was designed to provide high energy pulses from a small volume. Occupying slightly more than 350 in³, including power supply and electronics, this laser is unique. The scalable resonator design permits customization for different wavelengths, output energies, and powers.

SWIR Illumination

LIDAR/LADAR

Range Finding

Range-gated Imaging

Marker

3D Laser Radar

Laser Ionization Breakdown

Spectroscopy

- ✓ *Ruggedized*
- ✓ *Designed for airborne vibration and temperature*
- ✓ *Novel thermal management*
- ✓ *Compact, light-weight construction*
- ✓ *High wall-plug efficiencies*
- ✓ *On board diagnostics and data-logging*
- ✓ *Based on 50 Years of laser design experience*

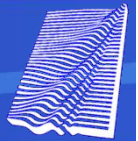

The A-TID-1572 was designed for laser radar and SWIR imaging applications where high energy pulses from a compact package are essential. The electronics and laser head can be packaged in alternate formats to fit in even tighter spaces. From conceptualization to final design the keyword has been extensibility. The A-TID-1572 can be configured to output energy at 1064 or 1572nm. Areté can also provide alternate Nd:YAG harmonics (532, 355, 266 nm) and higher output energies and different pulse repetition frequencies. A customized version of the A-TID may be right for your application. Contact us today for more information.

DEVICE SPECIFICATIONS **		A-TID-1572
Repetition Rate		≤ 30 Hz
Optical Characteristics	Output Power	1.2 W
	Pulse Energy	40 mJ
	Pulse Duration	~ 3 ns
	Beam Quality	M ² < 5
	Beam Size	4 mm
Wavelength		1572 ± 1 nm
Electrical Characteristics	Input Power (Typical / Max)	160 /260 W
	Voltage	24-36 VDC
Thermal Characteristics	Cooling Method	Conduction
	Heatsink Dissipation (Typical/Max)	160/260 W
	Heatsink Temperature	25± 4°
	Storage Temperature	-40 to 80°
Mechanical Characteristics	Weight	< 11 lbs
	Dimensions (L×W×H)	10.2 x 7.3 x 4.74 in.
** As part of our continuous product improvement, all specifications are subject to change without notice		

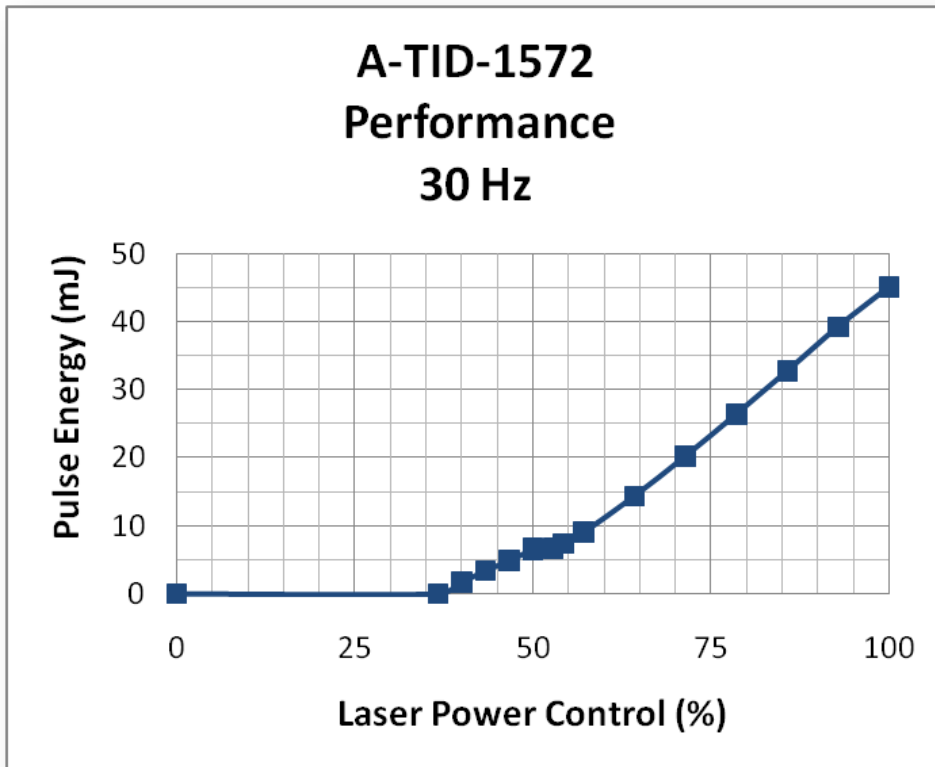
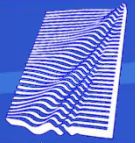

Far-field burn pattern of
1572 nm beam at 44 mJ

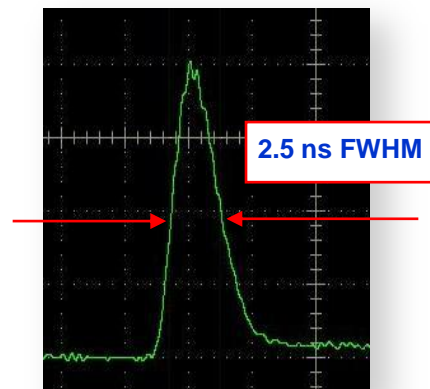

Pulse-capture of 1572 nm
beam at 44 mJ

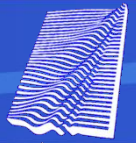

Electrical Interface

Power

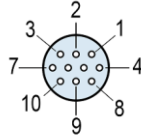

Glenair - Series 801 Circular, 10 Pin	
Pin No.	Description
1	Power In
2	Power In
4	Power In
5	Power In
8	Power In
3	Power Return
6	Power Return
7	Power Return
9	Power Return
10	Power Return

- Laser bulkhead connector
– P/N 801-009-07M7-10PA
- Mating cable connector
– P/N 801-008-16M7-10SA

Control

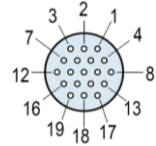

Pin No.	Description	
1	Host, RS-232, Receive	
2	Host, RS-232, Transmit	
5	Host, RS-232, Ground	
3	Debug, RS-232, Receive	Do not connect
7	Debug, RS-232, Transmit	Do not connect
6	Debug, RS-232, Ground	Do not connect
10	Interlock	Connect to Interlock Return
15	Interlock Return	
18	Laser Power Set Point - Analog	Analog voltage
17	Shield - Analog Ground	
12	External Trigger	High-Z TTL Input
16	External Trigger Return	
4	Laser Enable	High-Z TTL Input
8	Q-Switch Sync	High-Z TTL Output
9	External Return	Return for digital I/O
11	Fault Status	High-Z TTL Output
13	Laser Ready	High-Z TTL Output
14	Sync Out	High-Z TTL Output
19	External Return	Return for digital I/O

- Laser bulkhead connector
– P/N 801-009-07M9-19SA
- Mating cable connector
– P/N 801-008-16M9-19PA

A-TID -1572

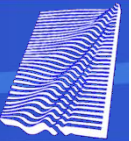

Areté
Associates

Areté Associates

We know systems... we know lasers

Mechanical Interface

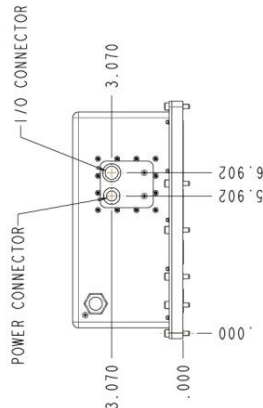
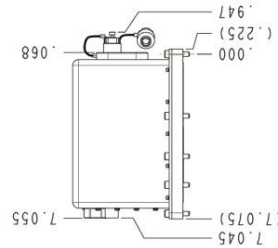
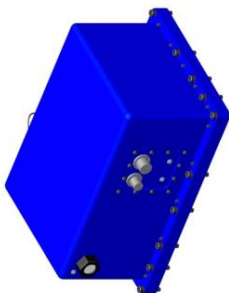
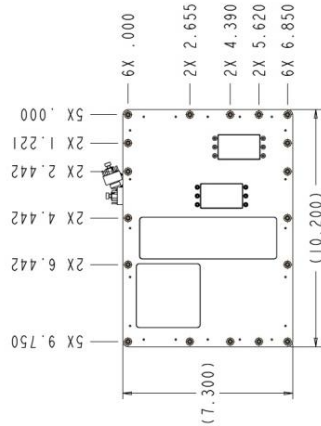
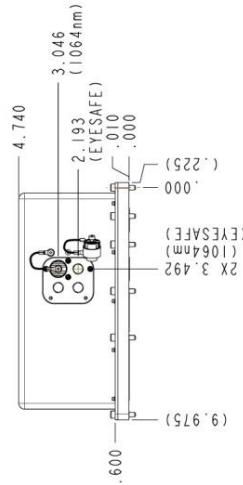
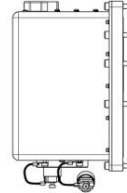
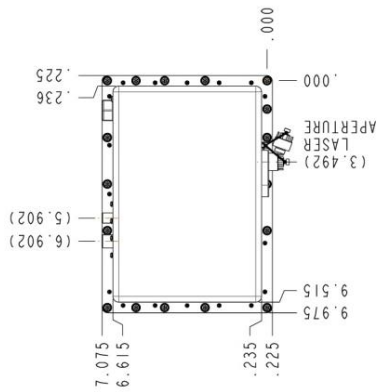
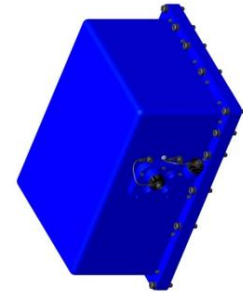

All dimensions in inches

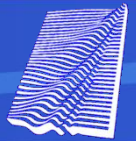

Thermal Interface

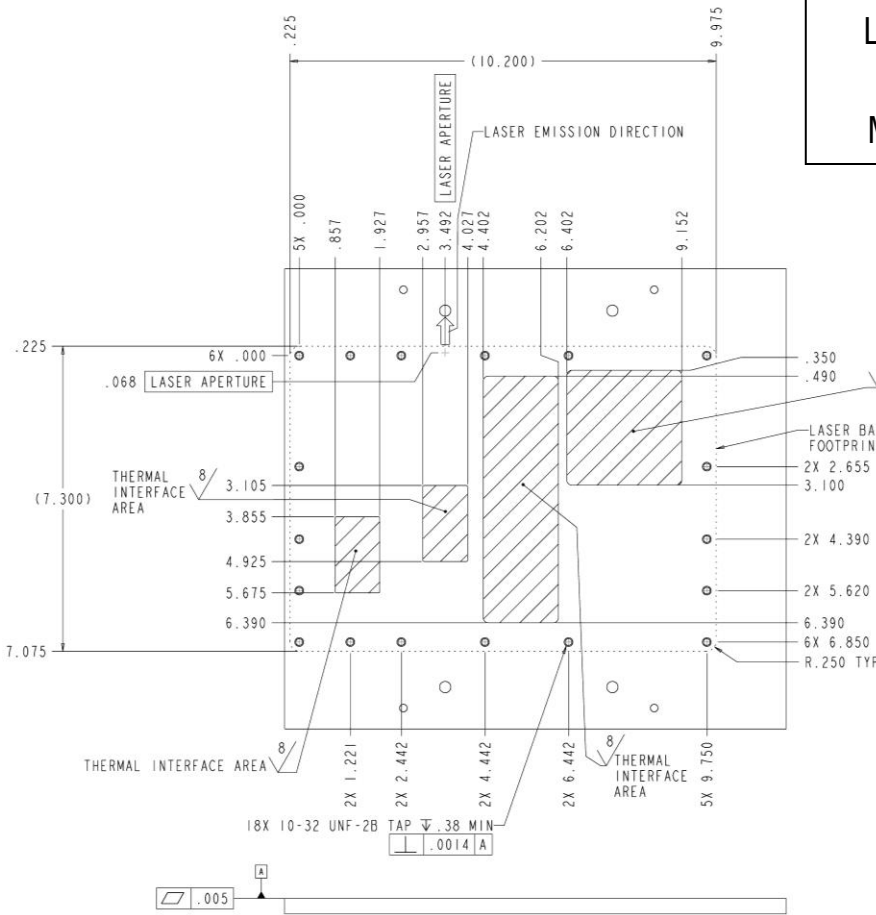

Laser Mounts to a Thermally Conductive Flat Plate
 Minimum size: 10.2 x 7.3 in.

T_{min}	21°C
T_{max}	29°C

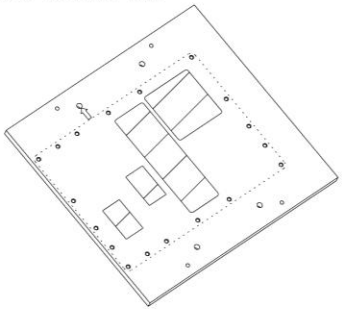

INDEX	DESCRIPTION	MATERIAL	QTY PER ASS'Y
6	THERMAL PAD 1	TennMax GP8025	2
7	THERMAL PAD 2	TennMax GP8050	1
8	THERMAL PAD 3	TennMax GP8050	1

